

TOP VIEW

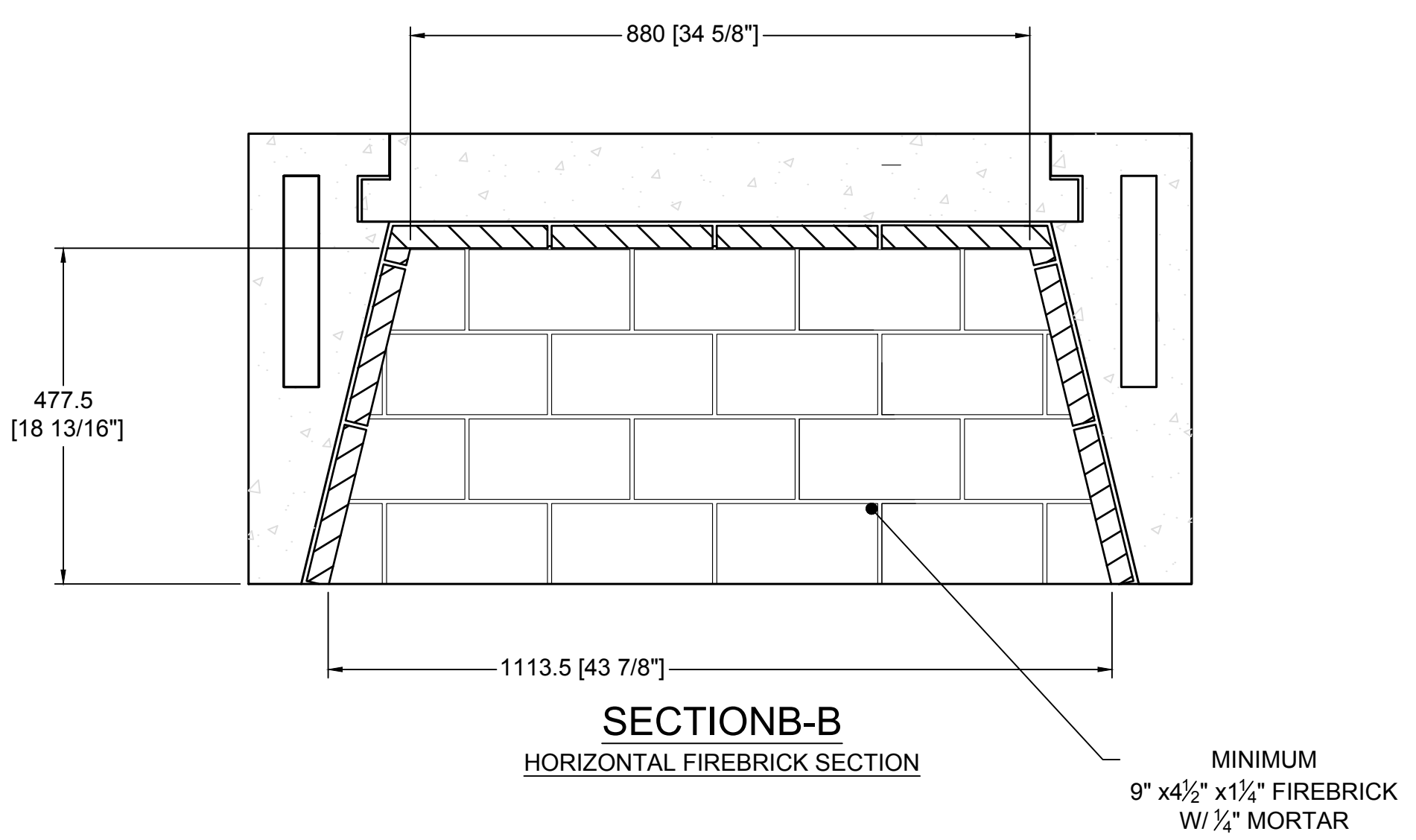

SECTION B-B  
HORIZONTAL FIREBRICK SECTION

MINIMUM  
9" x 4 1/2" x 1 1/4" FIREBRICK  
W/ 1/4" MORTAR

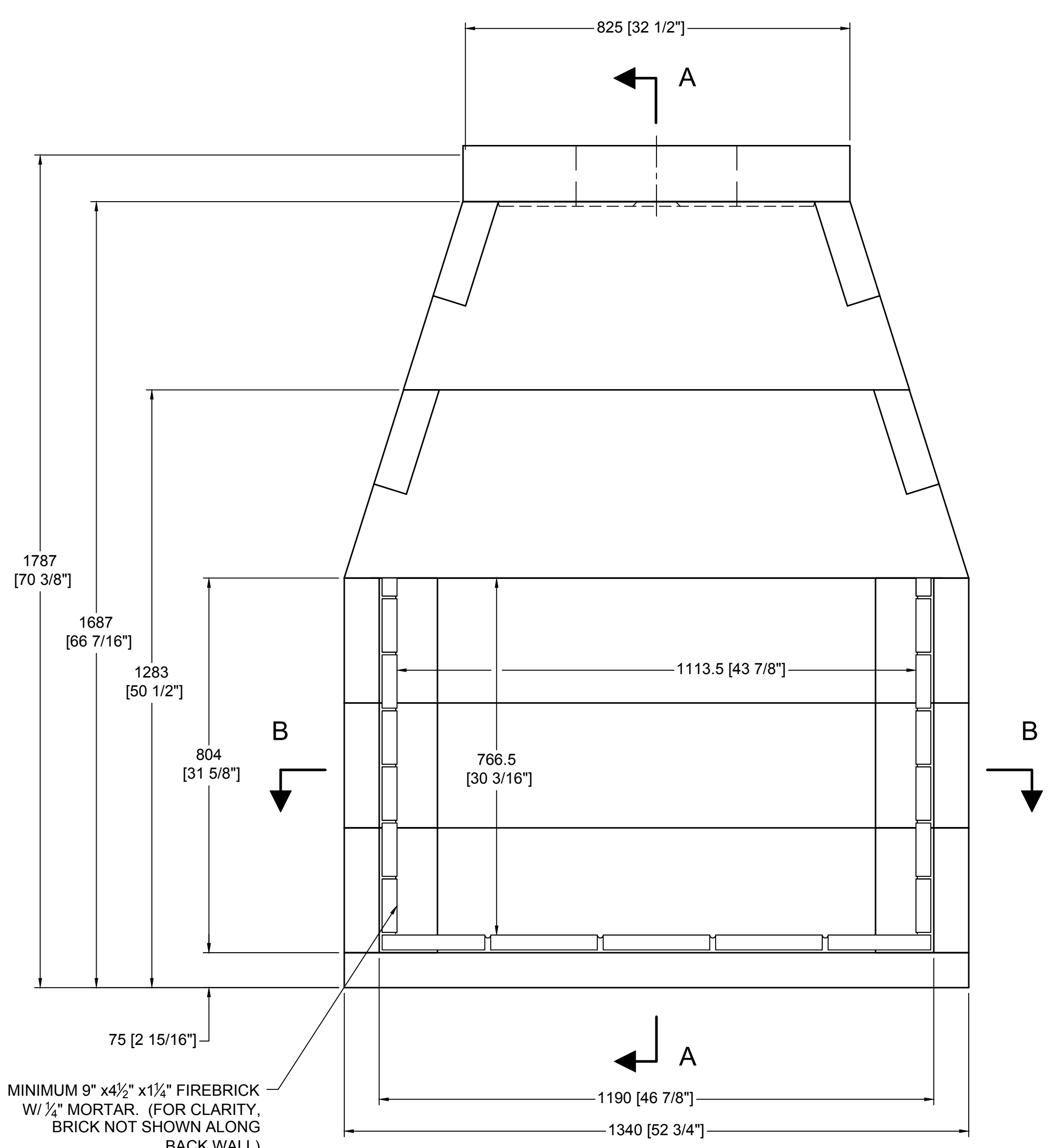

FRONT VIEW

MINIMUM 9" x 4 1/2" x 1 1/4" FIREBRICK  
W/ 1/4" MORTAR. (FOR CLARITY,  
BRICK NOT SHOWN ALONG  
BACK WALL)

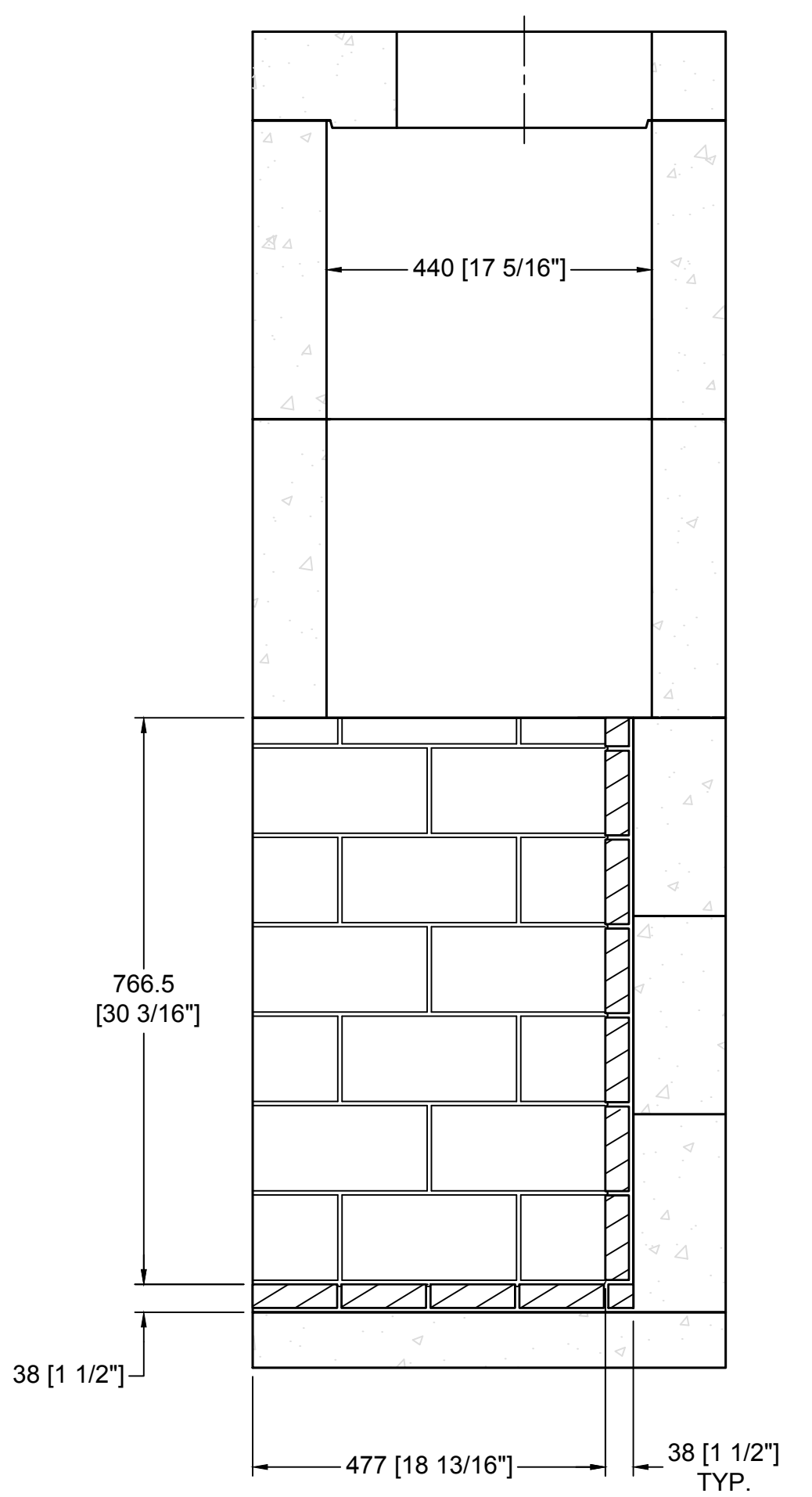

SECTION A-A  
VERTICAL FIREBRICK DETAIL

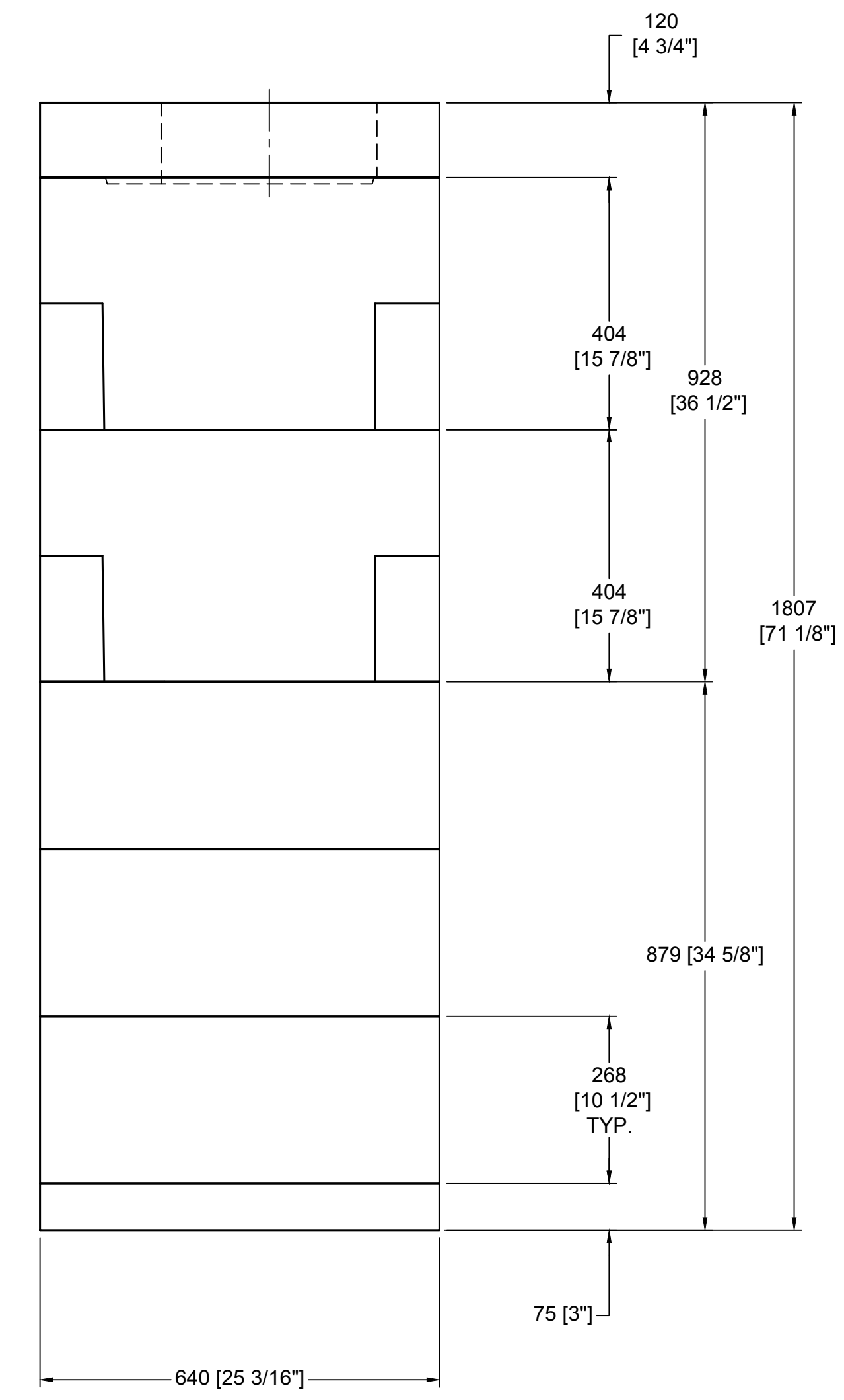

RIGHT-SIDE VIEW

COMPONENT LIST		
PART #	DESCRIPTION	QTY.
11	SMOKE DOME (MIDDLE)	2
13	SMOKE DOME (LARGE)	2
20	SIDEWALL	6
23	BASEPLATE-46" (STD)	1
31	BACKWALL-46" (STD)	3
34	TOP SLOPING	4
77A	TOP PLATE W/345mm HOLE	1

GENERAL NOTES

1. DRAWINGS ARE FOR DESIGN PURPOSES ONLY AND ARE THE SOLE PROPERTY OF EARTH CORE INDUSTRIES. ANY REPRODUCTION OR UNAUTHORIZED USE IS STRICTLY PROHIBITED.
2. EARTH CORE/ ISOKERN OR ANY DIVISION THEREOF SHALL NOT BE HELD LIABLE FOR ANY INCIDENTAL OR CONSEQUENTIAL DAMAGES OR EXPENSES ARISING OUT OF THE USE OF THE FIREPLACES OR CHIMNEY SYSTEMS.
3. ALWAYS CHECK LOCAL BUILDING CODES GOVERNING FIREPLACES AND FIREPLACE INSTALLATIONS.

ISOMETRIC VIEW (N.T.S)

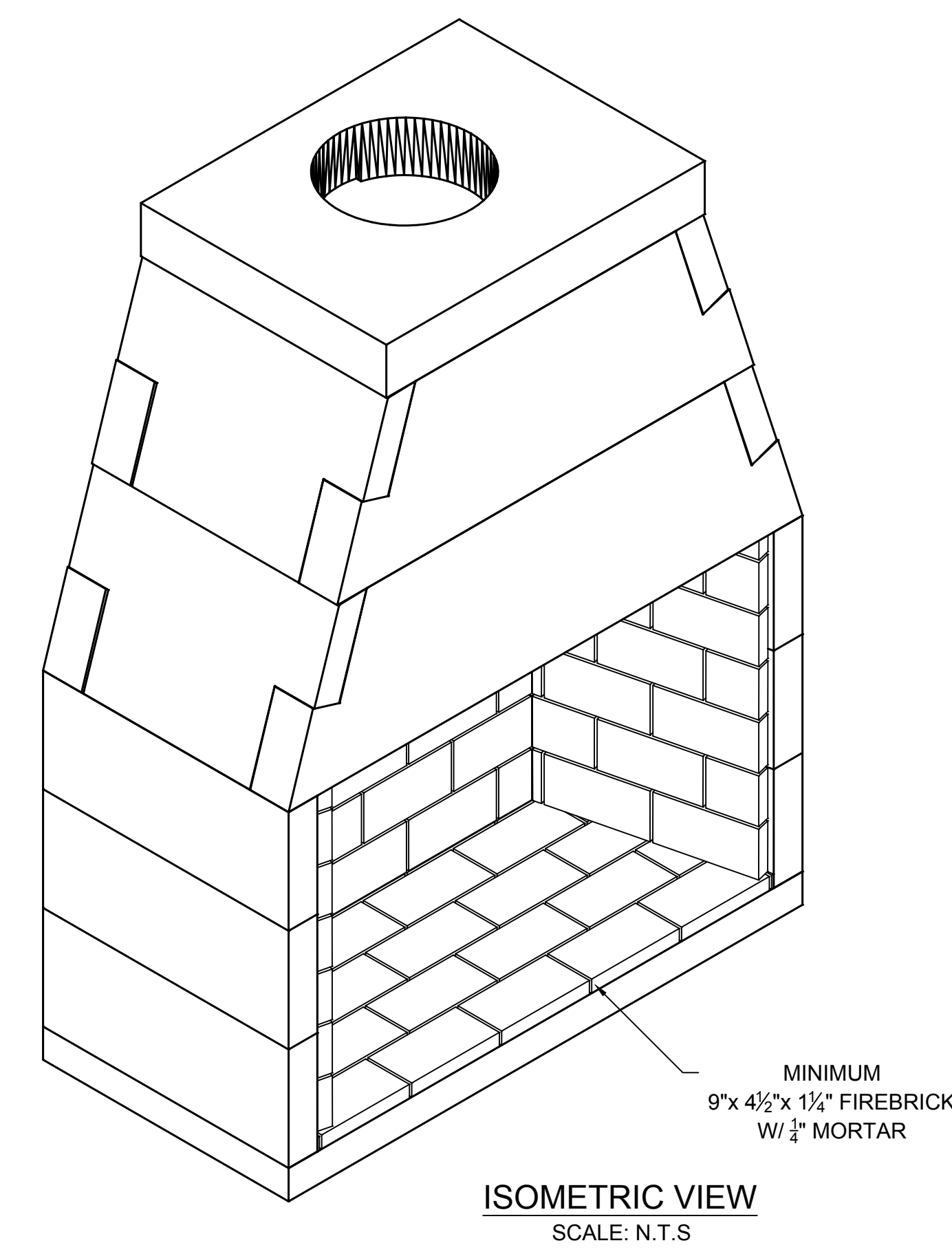

ISOMETRIC VIEW  
SCALE: N.T.S

	UNLESS OTHERWISE STATED, ALL DIMENSIONS ARE IN MILLIMETERS		PROJECT: 46" IBV SERIES				
	UNSPECIFIED TOLERANCES	THIRD ANGLE PROJECTION	DESCRIPTION: FIREPLACE CONSTRUCTION DOCUMENT				
MATERIAL: E.C. PUMICE MIXTURE	ANG. X ±		DRAWN: K.B.H.	DATE: 5/15/2017	SIZE: 1-1/2"=1'-0"	DRAWING #: 80B46	REV.
APPROVED:	LIN. X ±		DATE:	SCALE: D	DO NOT SCALE	SHEET # 1 OF 1	
	X ±						
	XX ±						

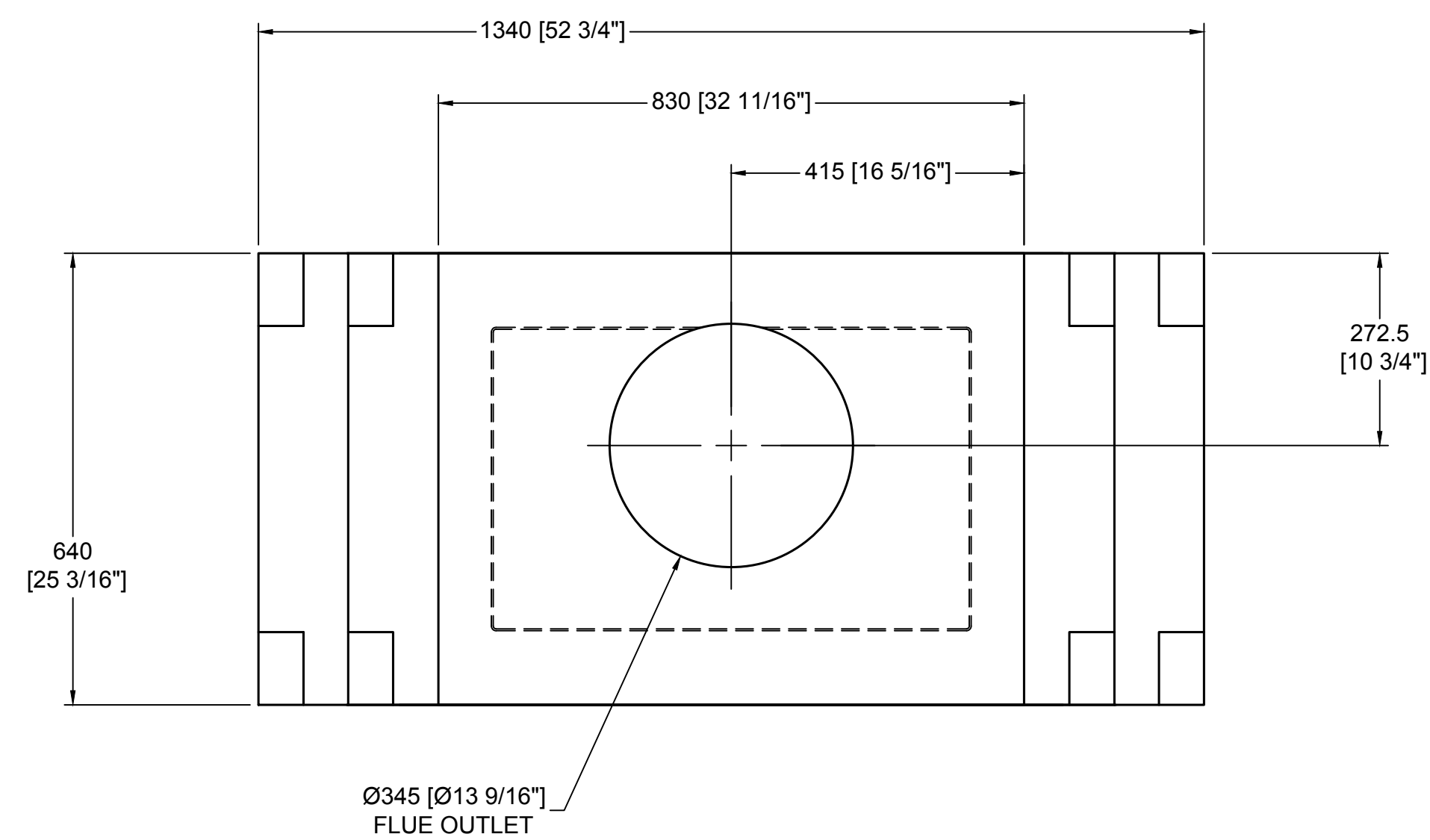

TOP VIEW

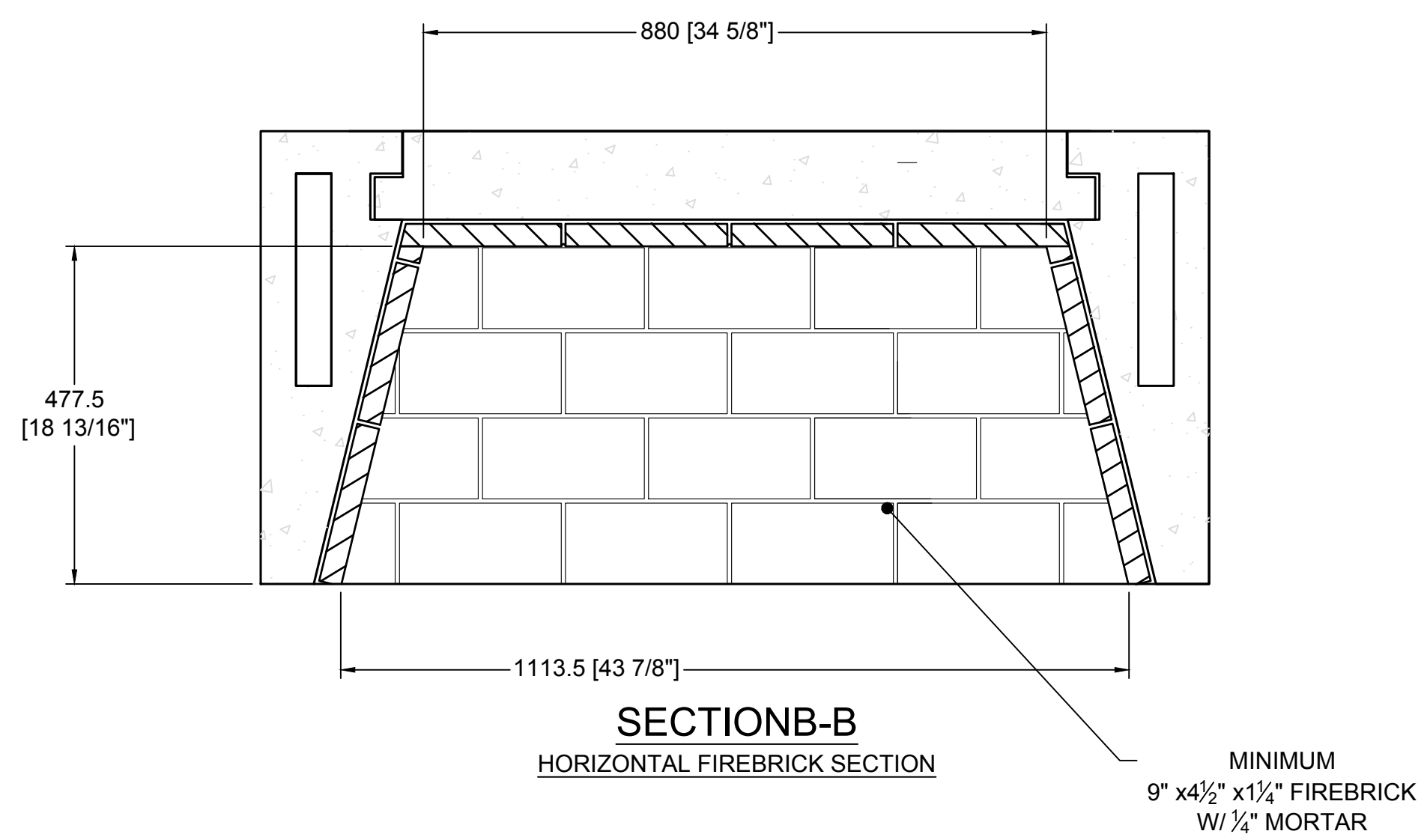

SECTION B-B  
HORIZONTAL FIREBRICK SECTION

MINIMUM  
9" x 4 1/2" x 1 1/4" FIREBRICK  
W/ 1/4" MORTAR

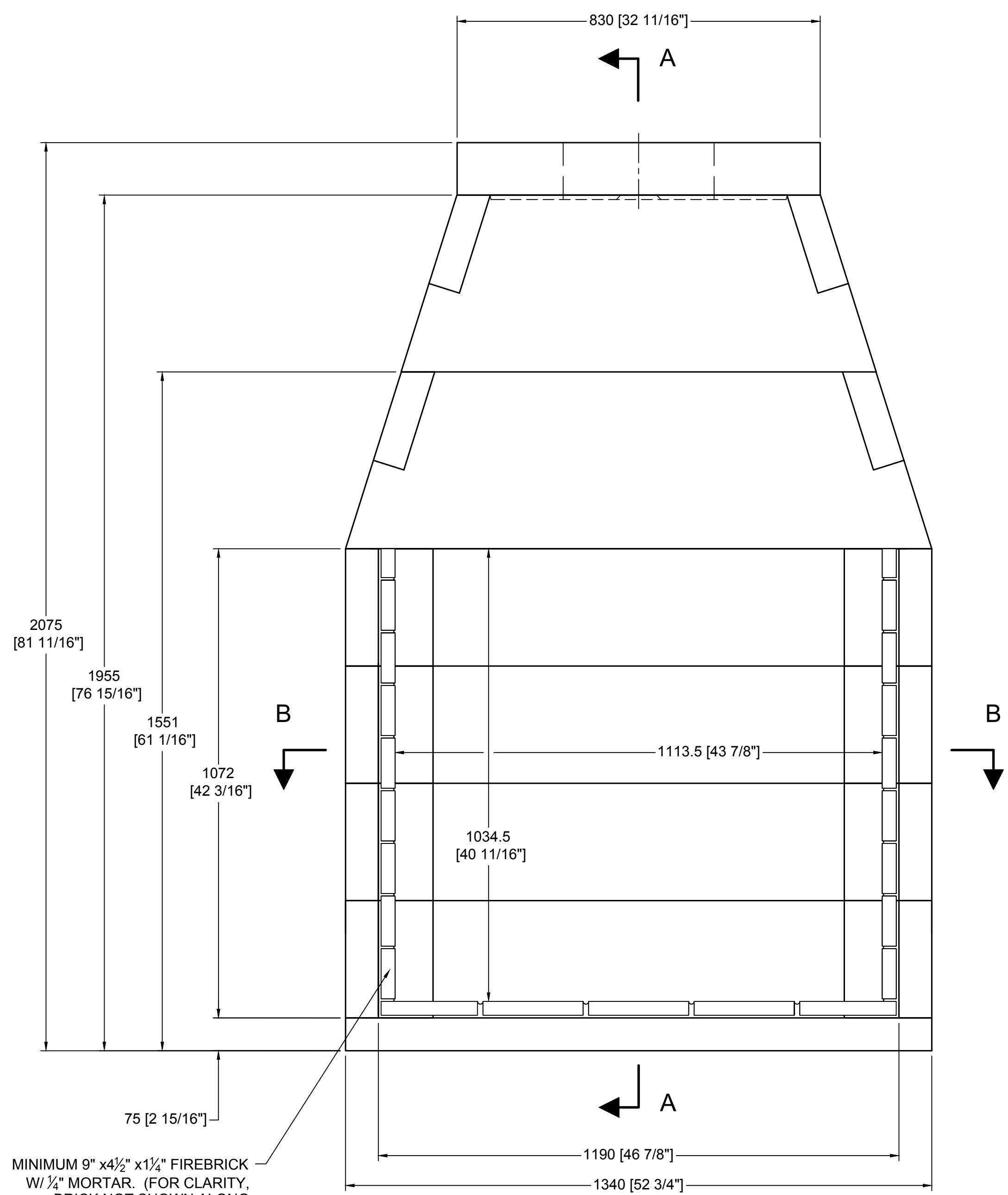

FRONT VIEW

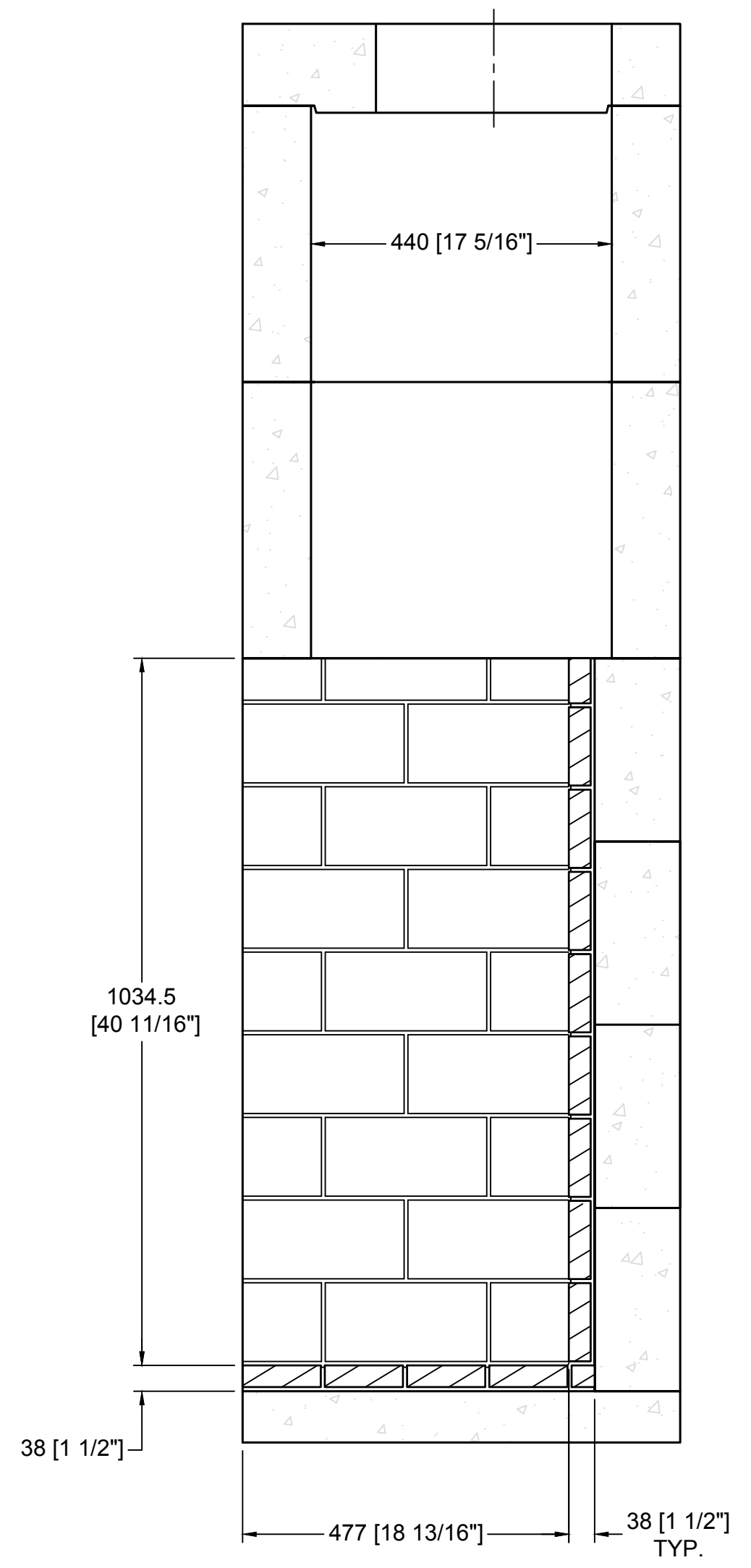

SECTION A-A  
VERTICAL FIREBRICK DETAIL

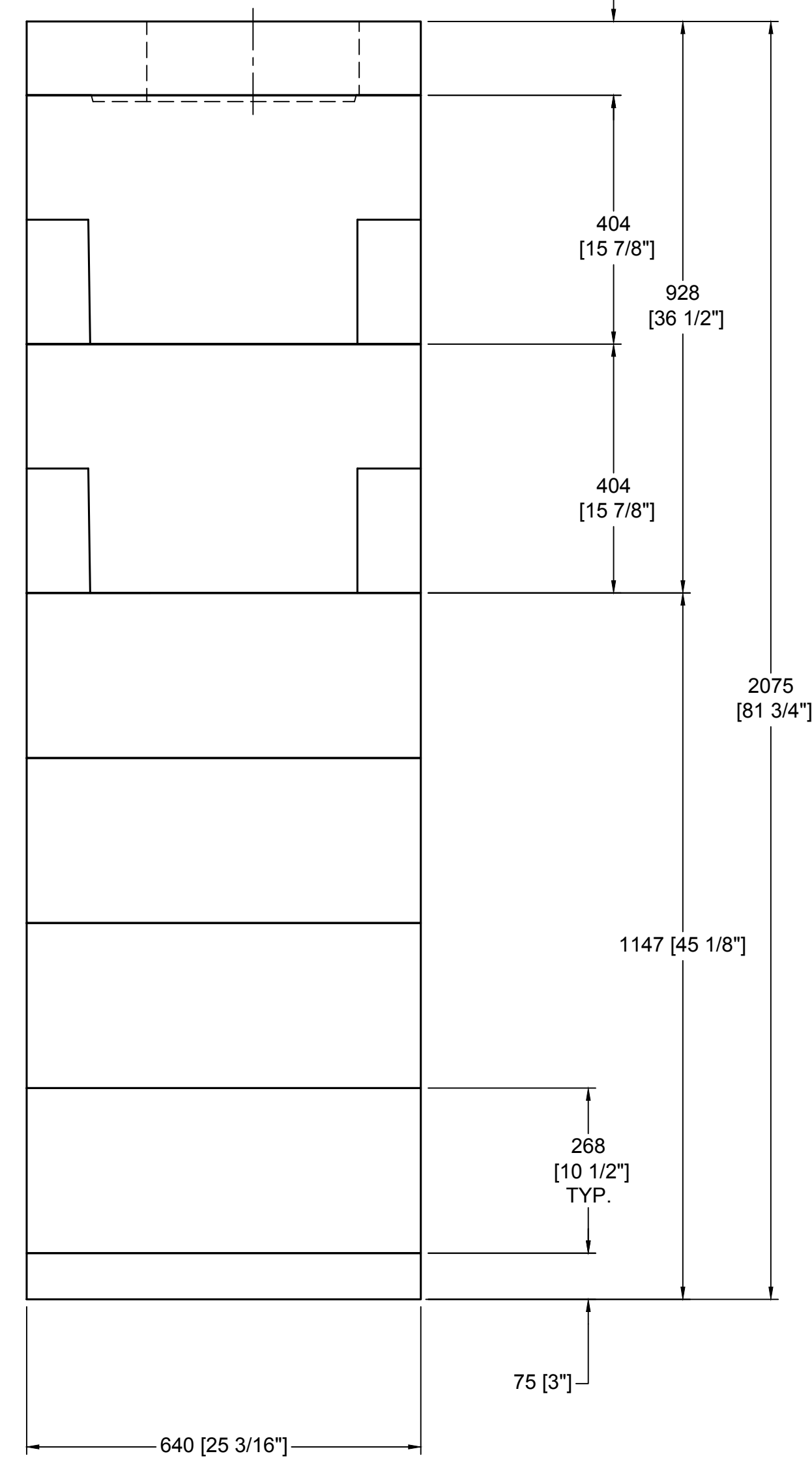

RIGHT-SIDE VIEW

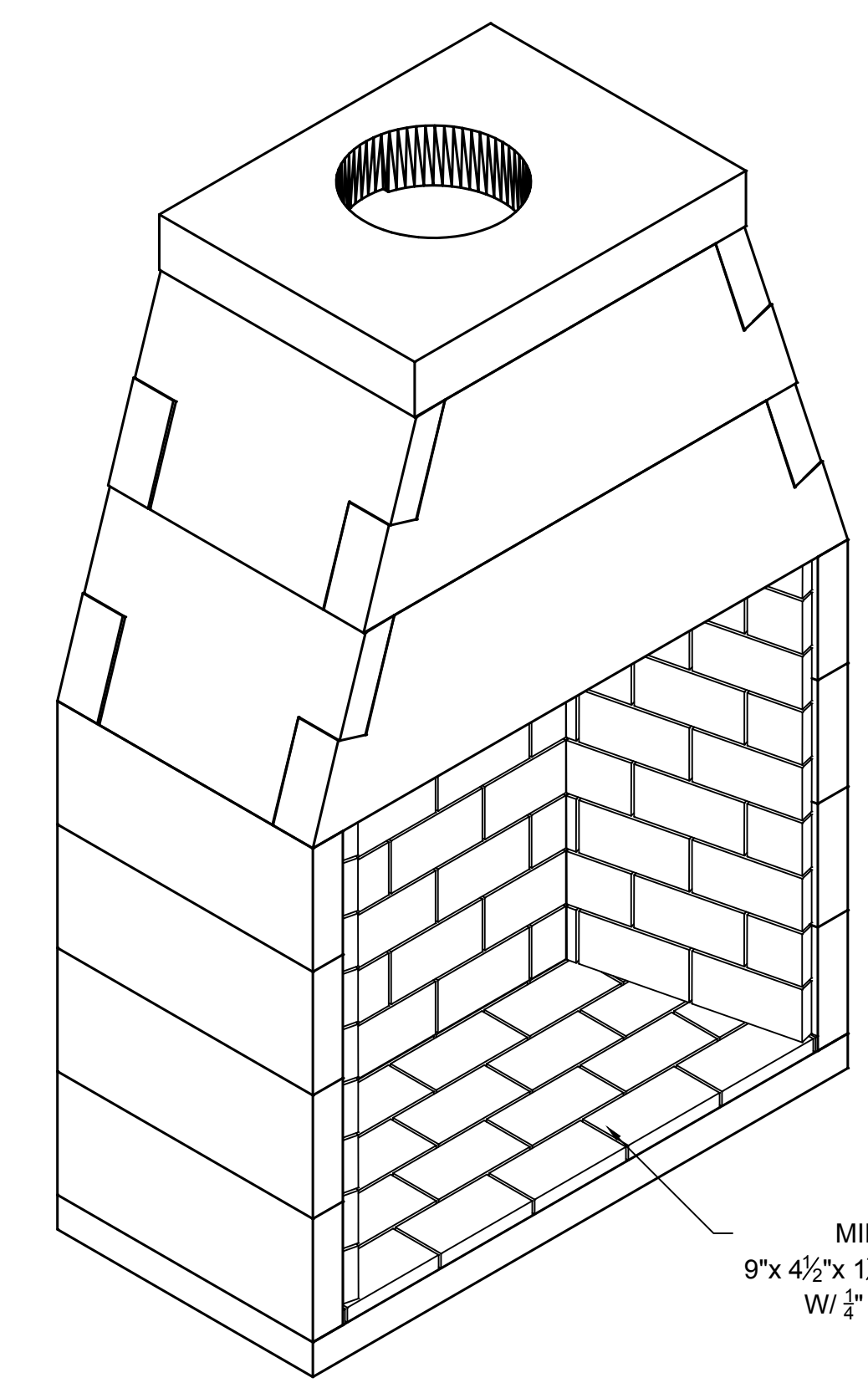

ISOMETRIC VIEW  
SCALE: N.T.S.

COMPONENT LIST		
PART #	DESCRIPTION	QTY.
11	SMOKE DOME (MIDDLE)	2
13	SMOKE DOME (LARGE)	2
20	SIDEWALL	8
23	BASEPLATE-46" (STD)	1
31	BACKWALL-46" (STD)	4
34	TOP SLOPING	4
77A	TOP PLATE W/345mm HOLE	1

**GENERAL NOTES**

- DRAWINGS ARE FOR DESIGN PURPOSES ONLY AND ARE THE SOLE PROPERTY OF EARTHCORE INDUSTRIES. ANY REPRODUCTION OR UNAUTHORIZED USE IS STRICTLY PROHIBITED.
- EARTHCORE/ ISOKERN OR ANY DIVISION THEREOF SHALL NOT BE HELD LIABLE FOR ANY INCIDENTAL OR CONSEQUENTIAL DAMAGES OR EXPENSES ARISING OUT OF THE USE OF THE FIREPLACES OR CHIMNEY SYSTEMS.
- ALWAYS CHECK LOCAL BUILDING CODES GOVERNING FIREPLACES AND FIREPLACE INSTALLATIONS.

ISOMETRIC VIEW (N.T.S)

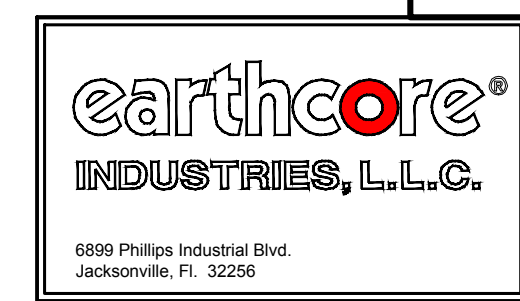

UNLESS OTHERWISE STATED, ALL DIMENSIONS ARE IN MILLIMETERS		PROJECT: 46" IBV SERIES (4 BLK)	
ANG.	X ±	DESCRIPTION: FIREPLACE CONSTRUCTION DOCUMENT	
LIN.	X ±	MATERIAL: E.C. PUMICE MIXTURE	
XX	±	DRAWN: K.B.H. DATE: 5/15/2017	
THIRD ANGLE PROJECTION		SIZE: D	SCALE: 1-1/2"=1'-0"
APPROVED:		DATE:	DRAWING #: 80B46
		DO NOT SCALE	SHEET # 1 OF 1

MINIMUM 9" x 4 1/2" x 1 1/4" FIREBRICK  
W/ 1/4" MORTAR. (FOR CLARITY,  
BRICK NOT SHOWN ALONG  
BACK WALL)

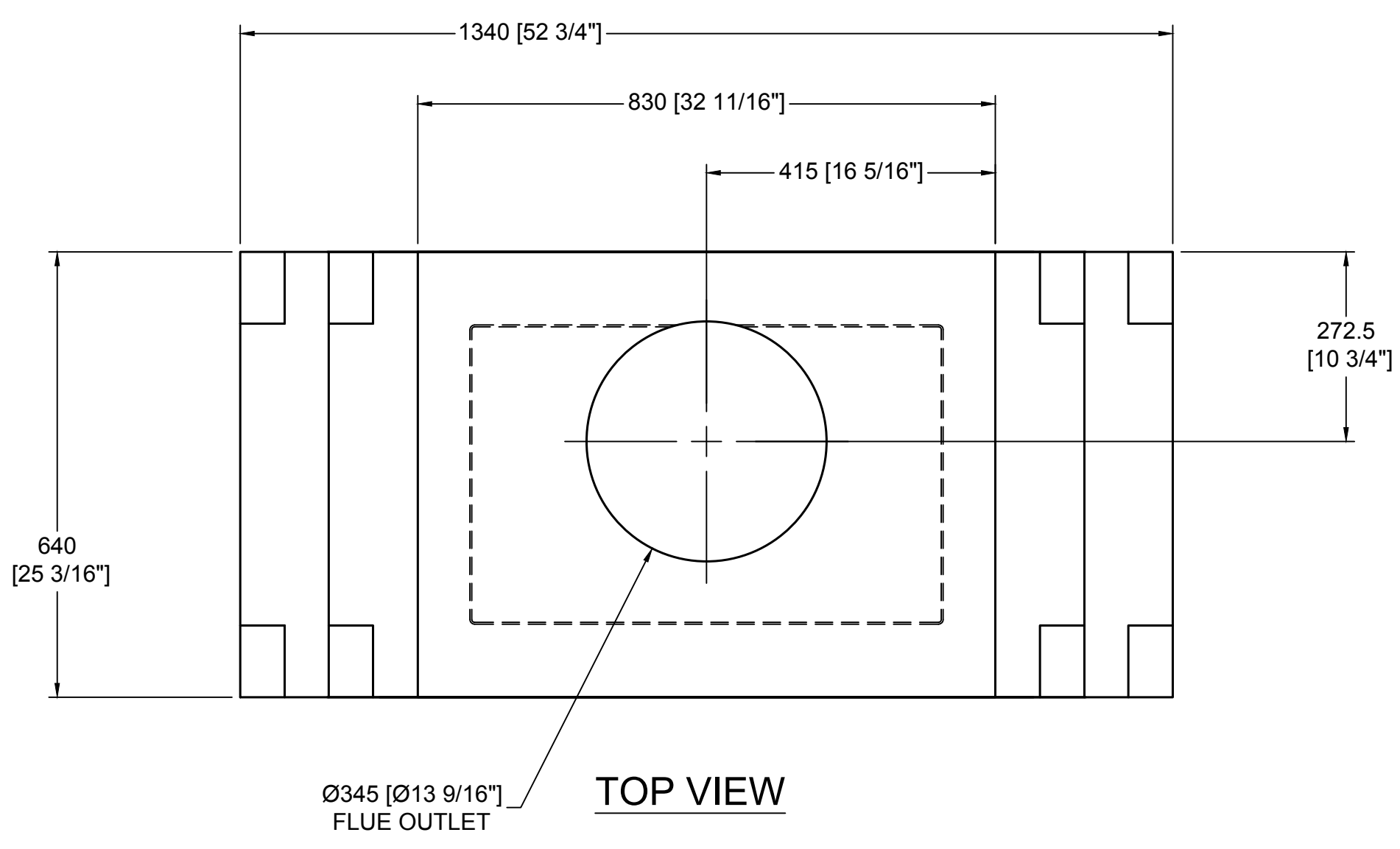

Ø345 [Ø13 9/16"]  
FLUE OUTLET  
**TOP VIEW**

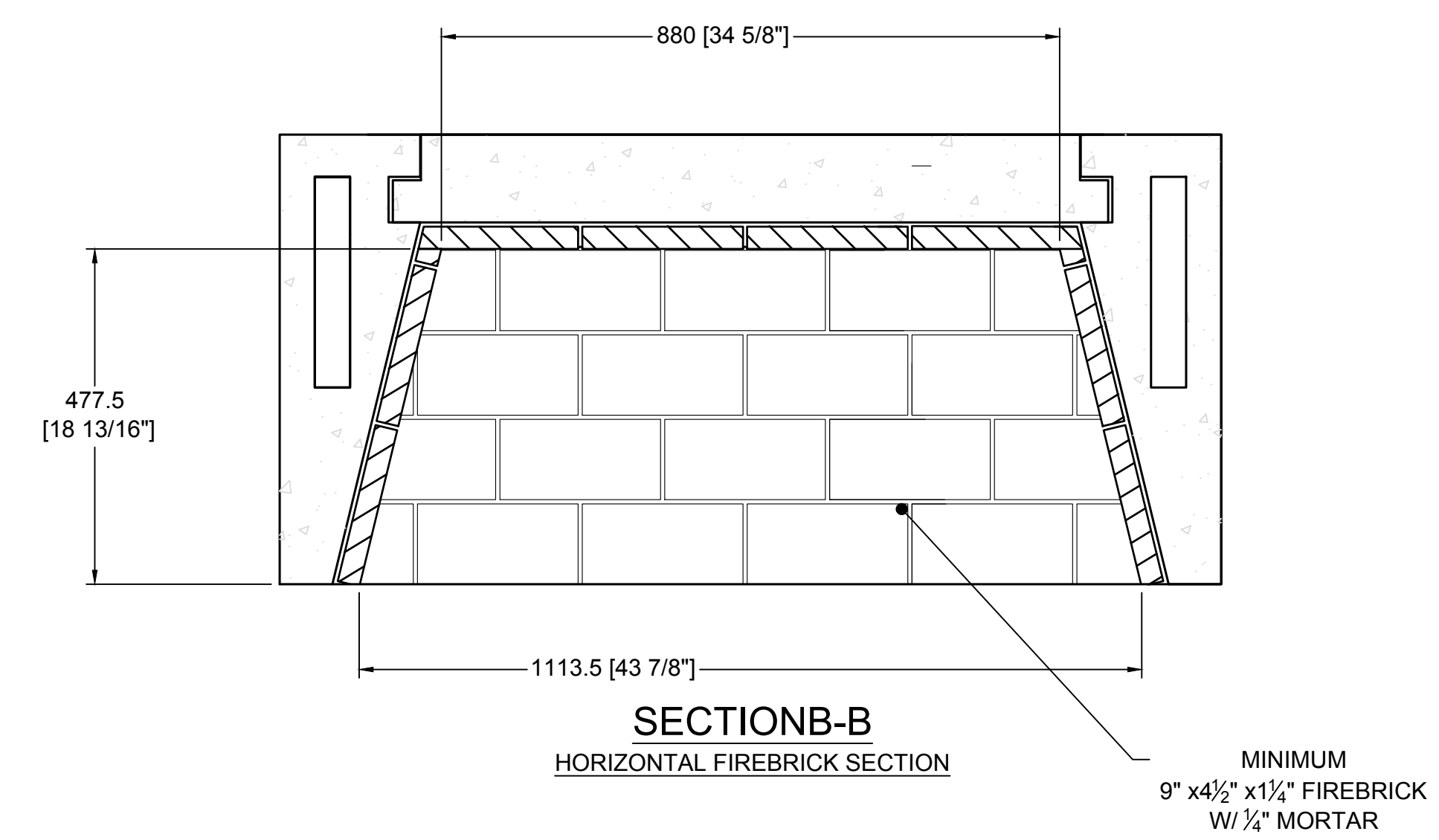

**SECTION B-B**  
HORIZONTAL FIREBRICK SECTION  
MINIMUM  
9" x 4 1/2" x 1 1/4" FIREBRICK  
W/ 1/4" MORTAR

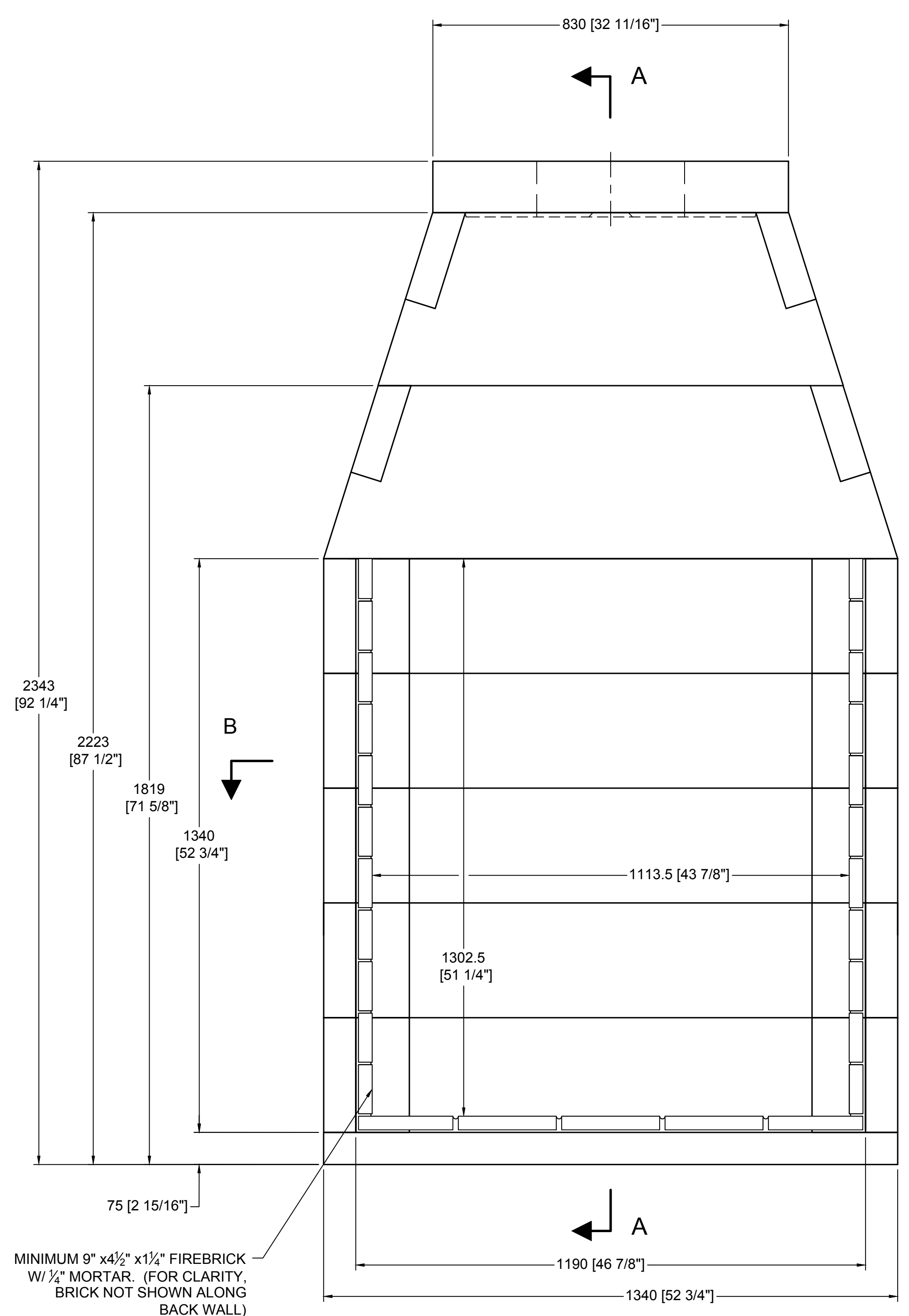

MINIMUM 9" x 4 1/2" x 1 1/4" FIREBRICK  
W/ 1/4" MORTAR. (FOR CLARITY,  
BRICK NOT SHOWN ALONG  
BACK WALL)

**FRONT VIEW**

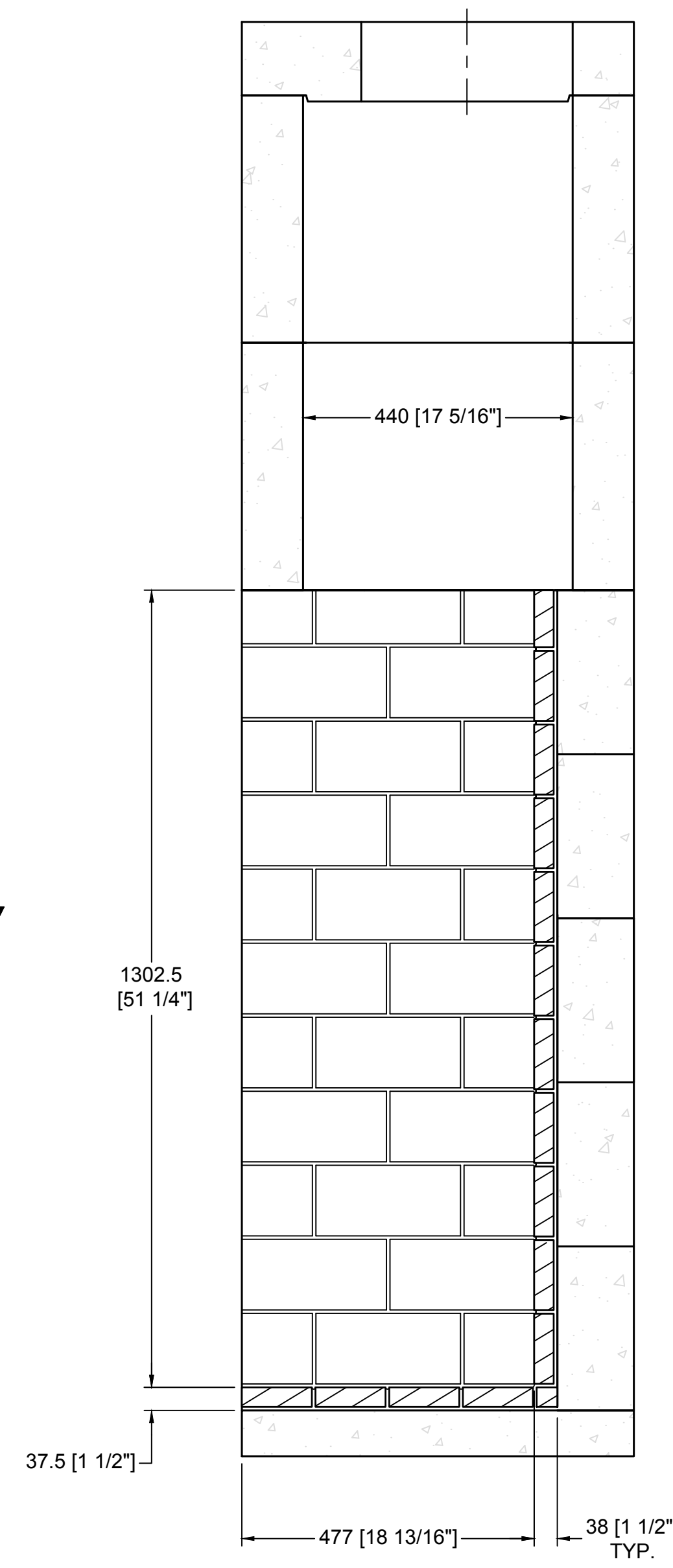

**SECTION A-A**  
VERTICAL FIREBRICK DETAIL

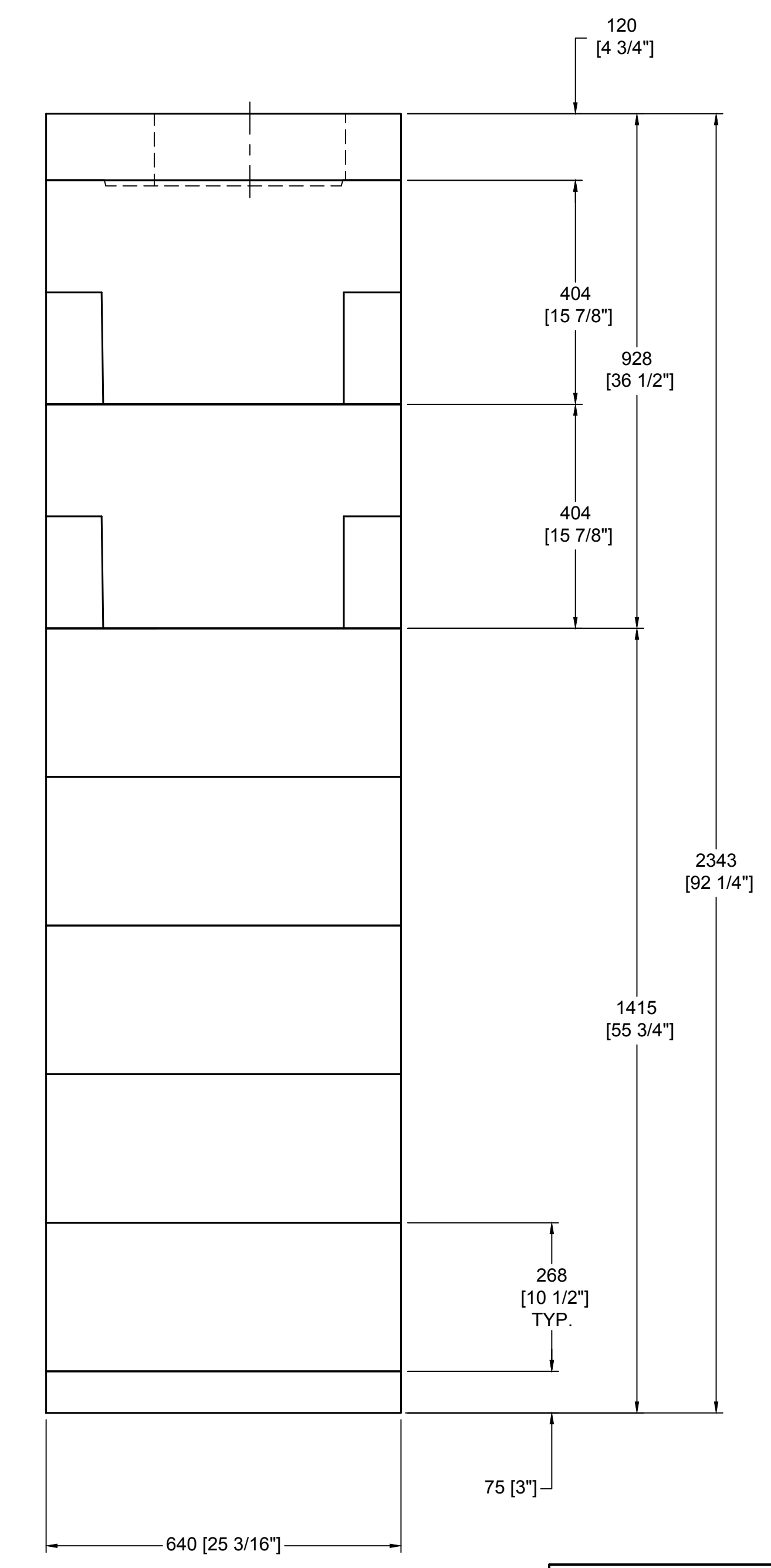

**RIGHT-SIDE VIEW**

COMPONENT LIST		
PART #	DESCRIPTION	QTY.
11	SMOKE DOME (MIDDLE)	2
13	SMOKE DOME (LARGE)	2
20	SIDEWALL	10
23	BASEPLATE-46" (STD)	1
31	BACKWALL-46" (STD)	5
34	TOP SLOPING	4
77A	TOP PLATE W/345mm HOLE	1

**GENERAL NOTES**

- DRAWINGS ARE FOR DESIGN PURPOSES ONLY AND ARE THE SOLE PROPERTY OF EARTHCORE INDUSTRIES. ANY REPRODUCTION OR UNAUTHORIZED USE IS STRICTLY PROHIBITED.
- EARTHCORE/ ISOKERN OR ANY DIVISION THEREOF SHALL NOT BE HELD LIABLE FOR ANY INCIDENTAL OR CONSEQUENTIAL DAMAGES OR EXPENSES ARISING OUT OF THE USE OF THE FIREPLACES OR CHIMNEY SYSTEMS.
- ALWAYS CHECK LOCAL BUILDING CODES GOVERNING FIREPLACES AND FIREPLACE INSTALLATIONS.

**ISOMETRIC VIEW (N.T.S)**

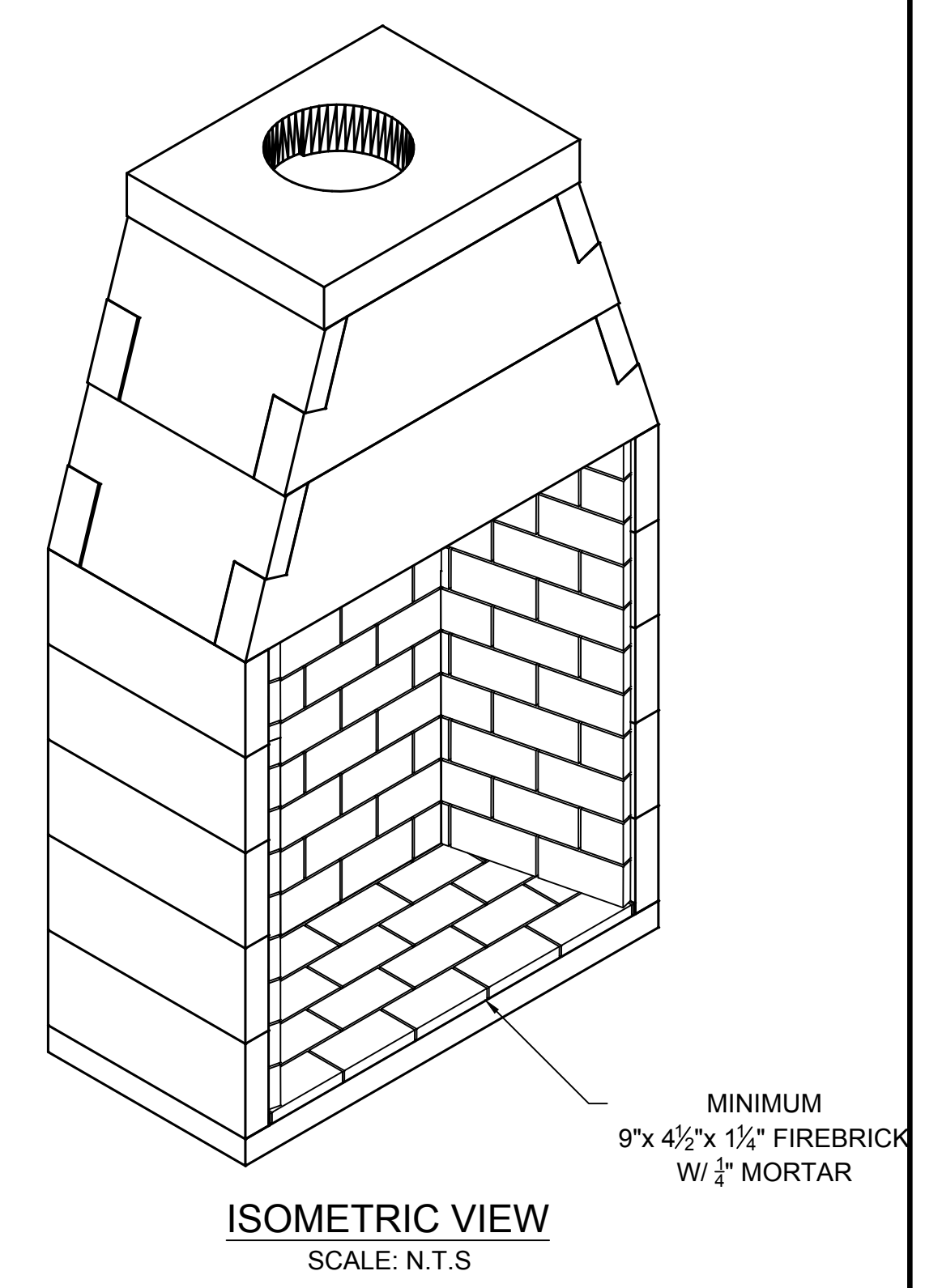

**ISOMETRIC VIEW**  
SCALE: N.T.S

 6999 Philips Industrial Blvd. Jacksonville, FL 32256	UNLESS OTHERWISE STATED, ALL DIMENSIONS ARE IN MILLIMETERS		PROJECT: <b>46" IBV SERIES (5 BLK)</b>		
	UNSPECIFIED TOLERANCES	THIRD ANGLE PROJECTION	DESCRIPTION: <b>FIREPLACE CONSTRUCTION DOCUMENT</b>		
	MATERIAL: <b>E.C. PUMICE MIXTURE</b>	DRAWING #: <b>80B46</b>			
	DRAWN: <b>K.B.H.</b>	DATE: <b>5/15/2017</b>	SCALE: <b>1-1/2"=1'-0"</b>	SHEET # <b>1</b> OF <b>1</b>	